

BOUNDARY GARD™ BX-80N



Read instructions completely before beginning installation.

- Optex presents a new concept, **BOUNDARY GARD™**, which protects a building's exterior by detecting intruders before an entry is attempted. In addition to signaling an alarm system, **BOUNDARY GARD™** can create an audible local alarm to deter intruders before a break-in occurs.
- BX-80N is a passive infrared detector which detects the infrared heat energy that is emitted by humans and is designed with this concept.

Features

- | | |
|--|---|
| <ol style="list-style-type: none"> 1. Double output terminals 2. Audible alarm · Area check mode 3. Limited detection range function 4. Size judging function 5. Waterproof 6. Double conductive shielding | <ul style="list-style-type: none"> - Individual N.O.& N.C. outputs. - BX-80N's built-in buzzer can sound an alarm while an alarm is occurring. This buzzer can also be used to announce detection during area check mode (See section 8-3 DIP Switch Setup). - Since both upper and lower fingers have to be blocked at the same time to be activated, the detection range of the BX-80N can be limited to avoid detecting unwanted object. - Upper and lower detection fingers must be blocked simultaneously to activate the detector. BX-80N does not detect objects which do not block the upper fingers. - IP rating : IP 55 - This patent listed shielding greatly reduces the chance of false alarms due to car headlights, sunlight and other ambient light sources. |
|--|---|

1. SAFETY-RELATED PRECAUTIONS

Before installation, make sure to read this instruction manual carefully for safe and effective product operation.

<p>Warning This icon denotes a situation involving the risk of serious injury or even death, if the warning given is ignored.</p>	<p>Caution This icon denotes a situation involving the risk of serious injury or damage to property if the warning given is ignored.</p>
--	---

⊘ This icon indicates actions to be avoid. Details of the actions to be avoided are written beside or near icon. (The icon on the left indicates that the product must not be disassembled)

<p>Warning</p> <p>Never use this product for any applications except as stated above or unexpected accidents can occur.</p>	<p>Warning</p> <p>Never attempt to disassemble or modify the product, which increases the risk of fire or damage of the product.</p>
<p>Warning</p> <p>Never attempt to connect the terminals to units which require higher power supply or current draw than its rating. It increases the risk of fire or damage to the product.</p>	<p>Caution</p> <p>Avoid applying water directly from buckets, hoses, or otherwise splashing water directly onto the product. It increases the risk of damaging the product.</p>

2. DETECTION AREA

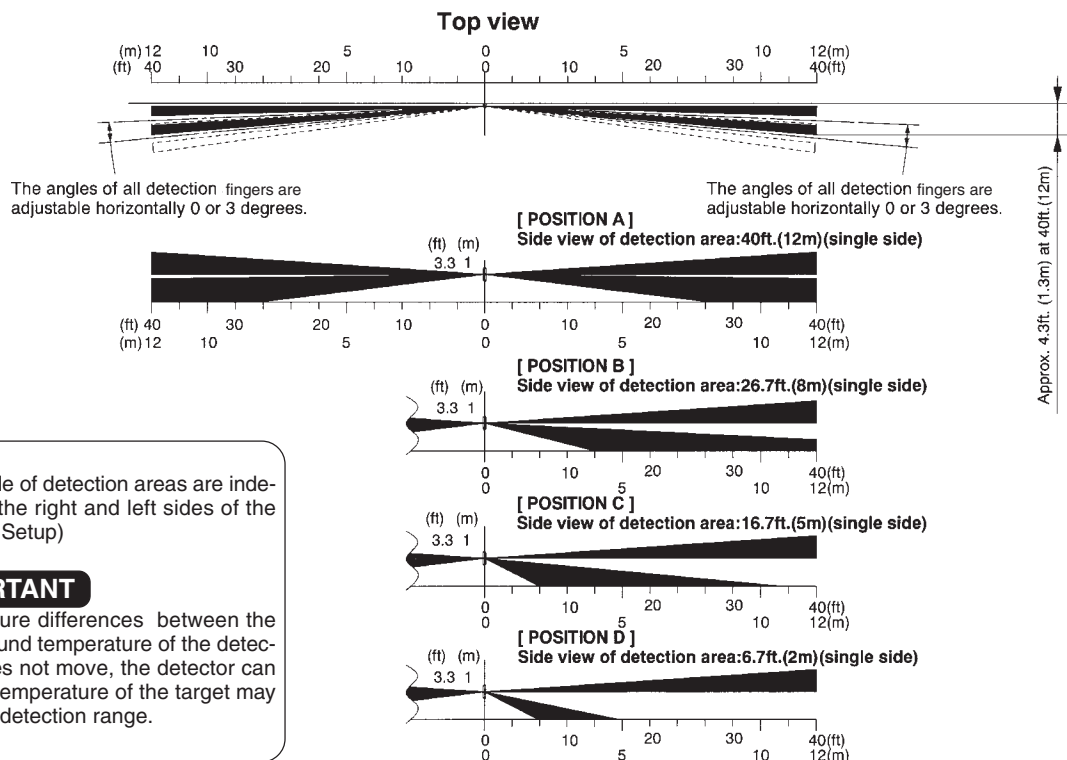

The horizontal and vertical angle of detection areas are independently adjustable on both the right and left sides of the detector. (See section 7 Area Setup)

IMPORTANT

This product detects temperature differences between the moving target and the background temperature of the detection area. So, if the target does not move, the detector can not detect it. Additionally, the temperature of the target may affect the detector's maximum detection range.

3. PARTS IDENTIFICATION

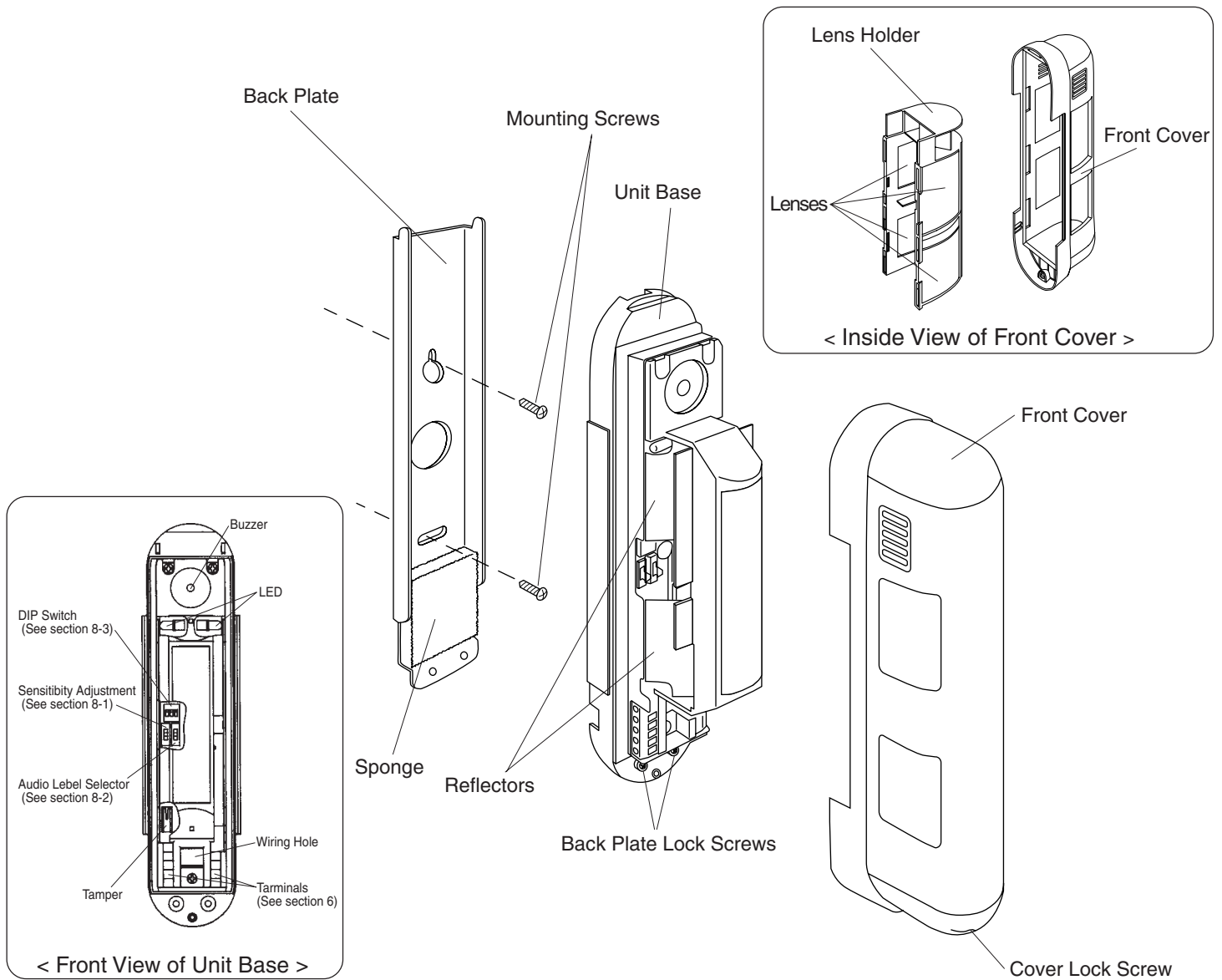

4. INSTALLATION HINTS

Refer to the following installation hints for best product operation. If you do not follow these installation hints there is the possibility that the unit will malfunction or not operate with its best performance.

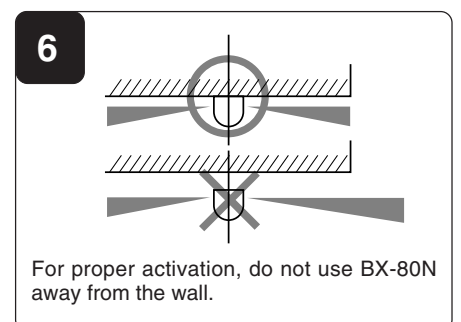
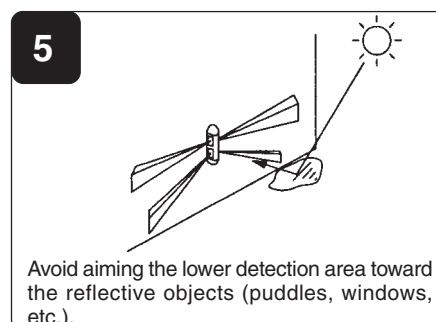
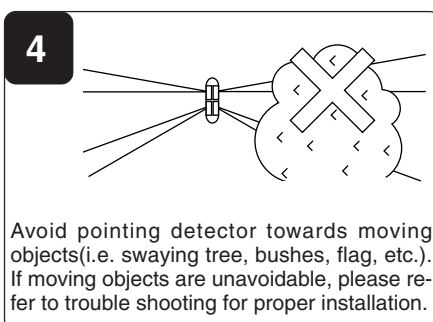
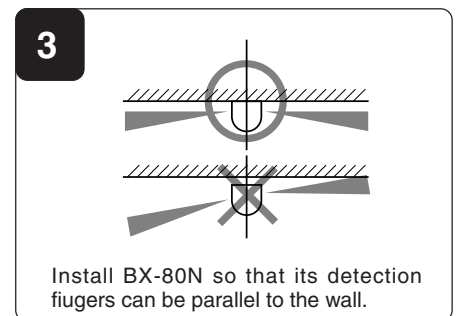
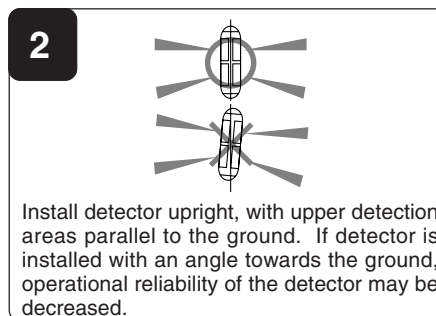
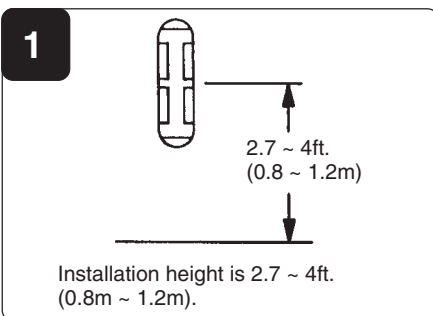

5. INSTALLATION

5-1. Before the Installation

1

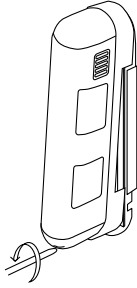

Loosen the cover lock screws and remove the front cover. Do not touch the lens surface.

2

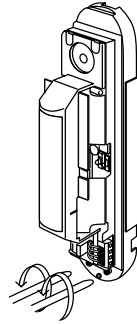

Loosen the back plate lock screws. Do not touch the reflectors.

3

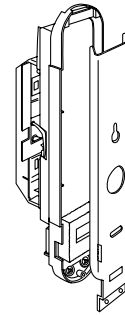

Remove the back plate by sliding it down and away from the unit base.

5-2. Installation Method

1

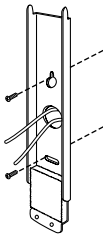

Lead wire through the wiring hole and install the back plate on the wall in an upright position by using provided mounting screws (two places). Installation height must be between 2.7ft. and 4ft. (0.8m and 1.2m).

2

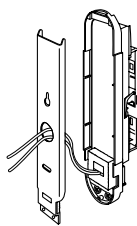

Lead wire through the wiring hole on the unit base and connect to the terminals (See section 6). Be sure to put the wires between sponges on the unit base and back plate for rain, dust and insect protection.

3

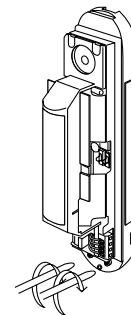

Set the unit base on the back plate, and fasten the back plate lock screws.

For exposed wiring

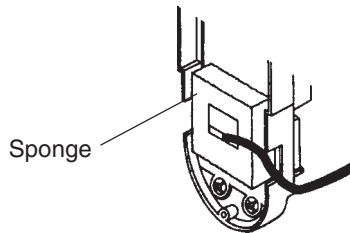

Lead wires through the wiring hole on the unit base and connect to the terminals. Then, lead wires to the wiring groove on the lower side of the unit base. Be sure to put the wires between sponges on the unit base and back plate for rain, dust and insect protection.

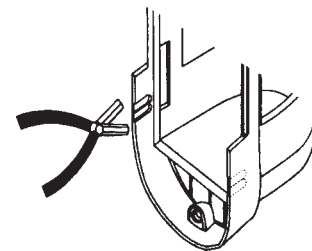

Remove the knockouts for the exposed wiring on one side of the front cover with pliers. After wiring, replace the front cover on the unit base.

6. WIRING

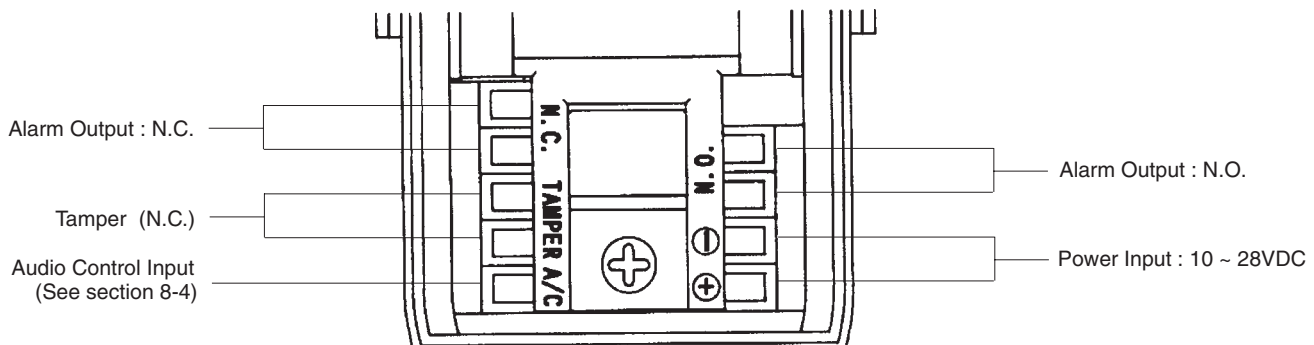

Wiring Distance

Power wires should not exceed following length. When using two or more units on one wire, the maximum length is obtained by dividing the wire length listed by the number of units used.

- UL requires BX-80N to be connected to a UL listed power supply cable of providing a nominal input of 12VDC, 38mA(MAX)(at 10~28VDC) and battery standby time of 4 hours.
- The equipment shall be installed in accordance with the National Electrical Code, NFPA 70.

Wire Size	Power Supply	
	12VDC	24VDC
AWG22 (0.33mm ²)	500ft. (150m)	1650ft. (500m)
AWG20 (0.52mm ²)	830ft. (250m)	2500ft. (760m)
AWG18 (0.83mm ²)	1300ft. (400m)	4000ft. (1200m)
AWG16 (1.31mm ²)	2000ft. (600m)	6000ft. (1800m)

7. AREA SETUP

7-1. Area Angle Adjustment

- If there are obstacles blocking the detection fingers, the angle of the fingers can be adjustable horizontally with the lens setting 0 or 3 degrees to keep a distance from the obstacles.
- Because of the detection technology (pulse count setting = 2) of BX-80N, both upper and lower detection fingers should be triggered for alarm activation. Therefore, make sure that the both detection fingers should be set at the same angle from the wall so that they are triggered at the same time. In this case, sensitivity [HI] is recommended when greater sensitivity is required around the rated area (near 12m).

IMPORTANT

Avoid adjusting the horizontal angles of only the upper or lower detection finger separately. BX-80N requires both upper and lower fingers to be blocked to make an alarm. So, if you adjust the horizontal angle of the detection areas, do it for both of them together. When the both angles are adjusted horizontally, sensitivity adjustment should be set to [HI] . (See section 8-1 Sensitivity Adjustment)

1

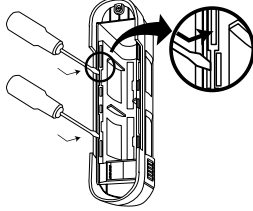

Unhook the three tabs on each side of the lens holder by inserting the blade of a screwdriver as shown above. Then, remove the lens holder from the front cover by holding the knobs on the lens holder.

2

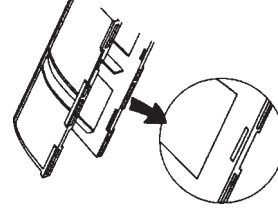

Move the lens to select the angle (0 or 3 degree) of the detection areas as shown above and confirm that the lens is unhooked from the groove on the lens holder.

3

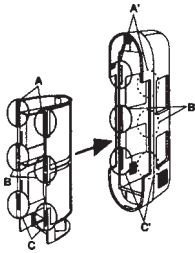

After selecting the detection area adjustment, replace the lens holder in the front cover by aligning the three tabs (A, B and C) on each side of the lens holder with the three grooves (A', B' and C') on the front cover.

4



If you select the 3 degree angle, the detection area will be 1.97ft.(0.6m) away from the wall at 40ft.(12m).

7-2. Detection Length Adjustment

- The upper detection finger stays parallel to the ground at all times. The lower detection finger moves as shown in this section depending on the position. So, the length of detection is limited by the angle of lower finger, since both upper & lower fingers have to be blocked at the same time to activate detector.

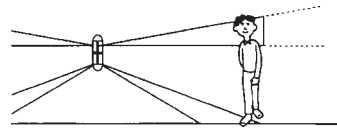

Both upper and lower fingers are blocked!
Detection!

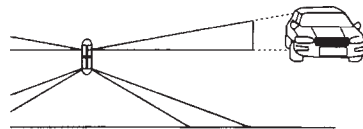

Only upper finger is blocked!
No
Detection

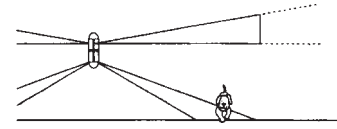

Only lower finger is blocked!
No
Detection

- Adjust the detection length by sliding the lower lens as shown. (The lower areas are adjustable on right and left sides independently.) Do not press hard.



Remove the lens holder from the front cover as described in section 7-1. The lower lens slides to adjust the detection length. Select the appropriate position from the guide on the lens holder (A,B,C or D). Make sure to conduct walk tests after changing the position. The LED lights and the area check mode (See section 8-3) can be used to identify detection areas. If the detection areas are not appropriate, re-adjust the detection length by sliding the lens to a different position on the lens holder.

- The lower detection finger can be adjusted to control the detection length as shown below:

[Detection length setting chart (single side)]

POSITION	A	B	C	D
DETECTION LENGTH	0~40ft 0~12m	0~26.7ft 0~8m	0~16.7ft 0~5m	0~6.7ft 0~2m

IMPORTANT

- Installation height must be between 2.7 ~ 4ft.(0.8m ~ 1.2m).
- The maximum detection length may vary as above due to environmental thermal conditions.
- Detection range depends on installation height.

POSITION [A] Side view of detection area:40ft.(12m) (single side)

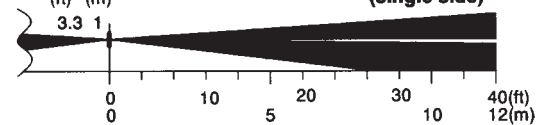

POSITION [B] Side view of detection area:26.7ft.(8m) (single side)

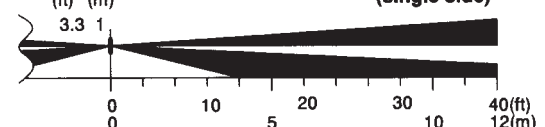

POSITION [C] Side view of detection area:16.7ft.(5m) (single side)

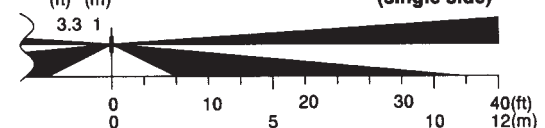

POSITION [D] Side view of detection area:6.7ft.(2m) (single side)

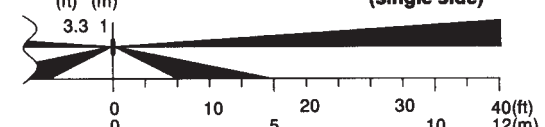

8. FUNCTION SETUP

8-1. Sensitivity Adjustment

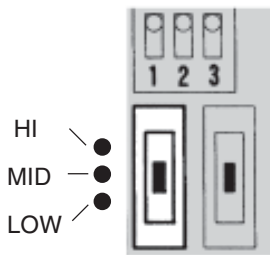

When greater sensitivity is desired, select [HI]. When the installation site is poor (bad conditions) select [LOW]. Sensitivity [HI] is recommended when:

1. the angles of detection areas are changed in horizontal direction.
2. greater sensitivity is required around the end of detection area (near 12m).

8-2. Audio Level Selector

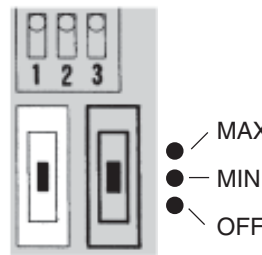

Set the audio level at proper volume during audible alarm function (See section 8-4) and/or area check mode (See section 8-3). Select [OFF] if neither function is used.

8-3. DIP Switch Setup

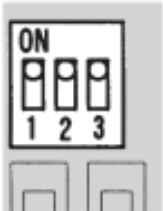

1. LED Indicator
2. Status Select

- Select LED indicator status : [ON] or [OFF].

- Control panel status adjustment for use with the audible alarm function feature. See section 8-4 to select configuration. Or, set to [OFF] if the audible alarm function will not be used.

3. Area Check Mode

- Select [Off] for normal operation or [ON] to activate the area check mode (Set volume in section 8-2).

- Regardless of the setting of switch 1,2, LED will be indicated and buzzer will sound while the area check mode is ON. Switch off the area checking mode during walk tests.

8-4. Audible Alarm Function

- The audible alarm function warns against intruders with a beep sound (approx.70dB) for 15 seconds when both upper and lower detection areas are blocked. This function can be controlled by program output of control panel.

Status Select (switch 2)

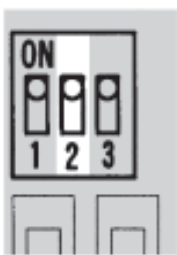

Armed : Open / High



Armed : Closed / Low

- Set the audible alarm function to beep when both upper and lower detection areas are blocked at the same time. Select [ON] or [OFF]. This function can be controlled remotely using switches or outputs from a control panel. Refer to the following chart for wiring instructions.

- When audio control input is not used, set the status select switch (switch 2) [OFF] (closed / low) if audible alarm function is used.

CP's Status		Detector Setting
Armed	Open : 5 ~ 18VDC	Armed : Open / High
Disarmed	Closed : 0 ~ 1VDC	
Armed	Closed : 0 ~ 1VDC	Armed : Closed / Low
Disarmed	Open : 5 ~ 18VDC	

< Wiring plans for audible alarm function only while control panel is armed. >

< Non-voltage type >

This wiring is required when there is no PGM output from control panel.

- In case there is no negative type output from the control panel.
- In the case there is negative type output or relay output (N.C. or N.O.) from the control panel.

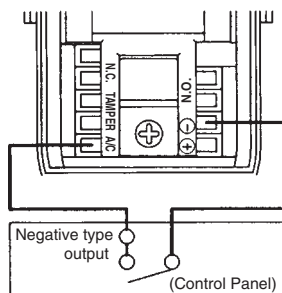
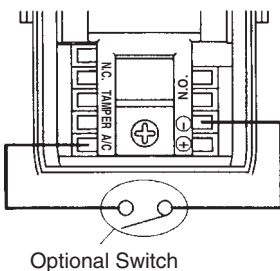

< Voltage type >

In case there is a programmable (PGM) output terminal (high or low) from the control panel.

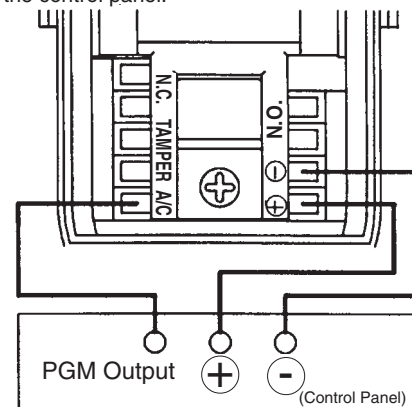

9. WALK TEST

Confirm detection area referring to this section.

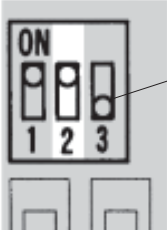

Referring to the section 8-3 DIP switch setup, switch on the area check mode, then adjust a desired detection area.

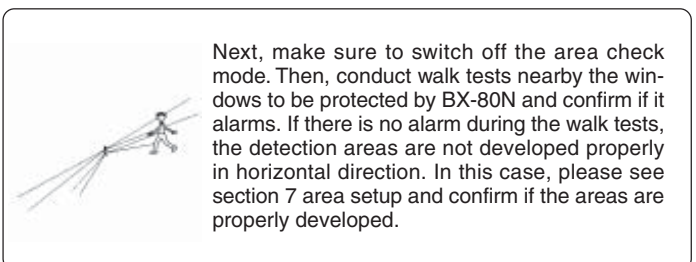

Next, make sure to switch off the area check mode. Then, conduct walk tests nearby the windows to be protected by BX-80N and confirm if it alarms. If there is no alarm during the walk tests, the detection areas are not developed properly in horizontal direction. In this case, please see section 7 area setup and confirm if the areas are properly developed.

- Walk test should be conducted annually.

If LED and buzzer are not activated when detection fingers are blocked, or LED and buzzer are activated while there is nothing to detect in detection area, see section 11 Trouble Shooting.

10. SPECIFICATIONS & DIMENSIONS

Model	BX-80N
Detection Method	Passive Infrared
Coverage	80ft. (24m) (40ft.(12m) on each side)
Detection Zones	4 zones (2 zone on each side)
Sensitivity	3°F at 2ft./s (1.6°C at 0.6m/s)
Detectable Speed	1~6.7ft./s (0.3~2.0m/s)
Power Input	10~28V DC
Current Draw	28mA (normal) 38mA (max)
Alarm Period	2.0±1.0 sec.
Relay Output	2 relay outputs N.O.and N.C. 28VDC 0.2A(MAX).each.
Tamper Switch	N.C. Opens when cover removed.
Test Mode	ON / OFF
Warm-up Period	Approx. 45 sec. (LED blinks)
Volume	Approx.70 dB (at 1m distance)
LED Indicator	LED is blinking during warm-up period alarm condition
Operating Temperature	-4~+122°F (-20°C ~+50°C)
Environmental Humidity	95% (MAX.)
RF Interference	No alarm 20 V/m
Mounting	Wall (Indoor/Outdoor)
Mounting Height	2.7~4ft. (0.8~1.2m)
Weight	14oz (400g)
IP rating	IP55
Accessories	Mount screw (4×20) × 2

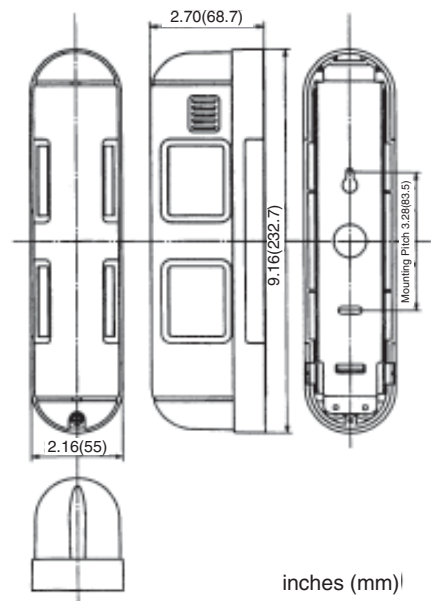

- ※ For UL certificated Installations, the sounder (audible alarm) may not be used as the primary audible device for a burglar alarm system.
- ※ Specifications and design are subject to change without prior notice.

11. TROUBLE SHOOTING

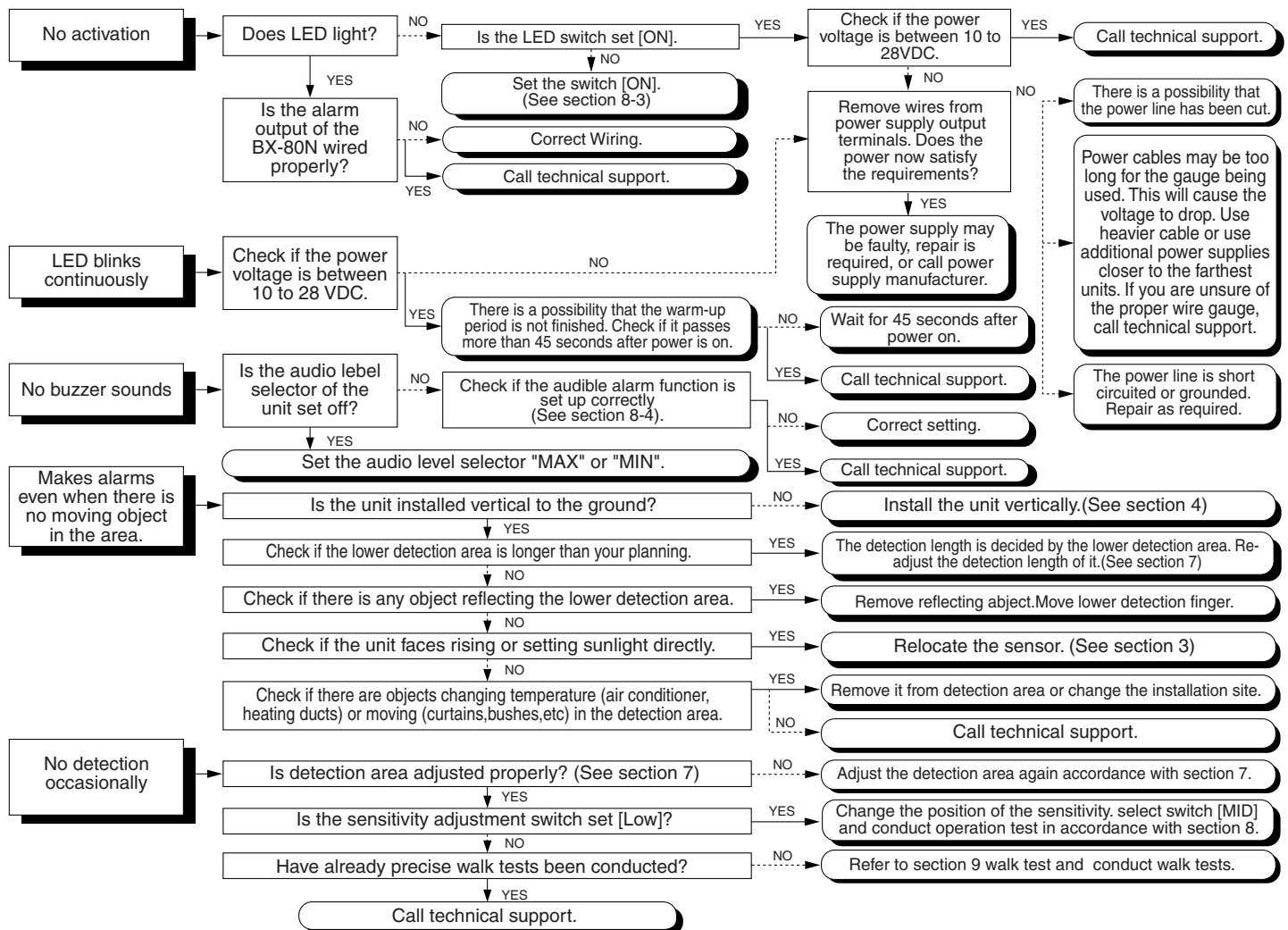

This unit is designed to detect movement of an intruder and activate an alarm control panel. Being only a part of a complete system, we cannot accept responsibility for any damages or other consequences resulting from an intrusion.

This product conforms to the EMC Directive 89/336 EEC.



OPTEX CO., LTD. (ISO 9001 Certified by LRQA)
4-7-5 Nionohama Otsu 520-0801 Japan
TEL (077)524-6047 FAX (077)522-9022

OPTEX INCORPORATED
1845W 205th St. Torrance, CA. 90501-1510 U.S.A.
TEL (310)533-1500 FAX (310)533-5910

OPTEX (EUROPE) LTD. (ISO 9002 Certified by NQA)
Unit 9, Four Seasons Crescent, Sutton, Surrey. SM3 9QR. UK
TEL (02082)542222 FAX (02086)410017